

6720

the benchmark in POS weighing

- ◆ **Spacious Footprint** 12" x 14" stainless steel dished platter.
- ◆ **Easy to Read** Six-digit LCD display with large 0.5" characters.
- ◆ **Accurate and Reliable** Precision load cell and quality electronics ensure repeatable weight measurements and trouble-free operation.
- ◆ **Simple to Use** Reduces operator training time.
- ◆ **Easy to Install** Interfaces to most electronic cash registers and point-of-sale software programs.



Point-of-sale interface scale for linking to electronic cash registers or POS terminals.



shown with internal display and optional remote post display



shown with remote display

Avery Berkel

perfect pizzas and a healthier bottom line

- ◆ **Interfaces** RS-232, 4-bit parallel, 40-bit serial, and OPOS.
- ◆ **Interface Protocols** ECR (NCI Standard), Mettler Toledo, CAS.
- ◆ **Quick Disconnects** Make all cable connections easily.
- ◆ **Construction** Die-cast base and load bridge reduces overall scale deflection and provides overload protection to safeguard load cell and extend life of scale.

NCI Model 6720 is designed for use in grocery and health food stores, cafeterias, convenience stores, candy shops, hardware stores, pet stores or other retail locations.

OPTIONS

- ◆ **Display Post** 12" high post for attachment to remote display.
- ◆ **Remote Display** Six-digit LCD housed in an extruded metal enclosure with tactile keys and a 7 ft. cable.
- ◆ **International Power Supply** 230 VAC, 50 Hz power supply. Cable terminated with a universal connector.
- ◆ **PC Interface Cable** RS-232 serial pass-through cable with DB-9 pin female connector to PC.

DIMENSIONS

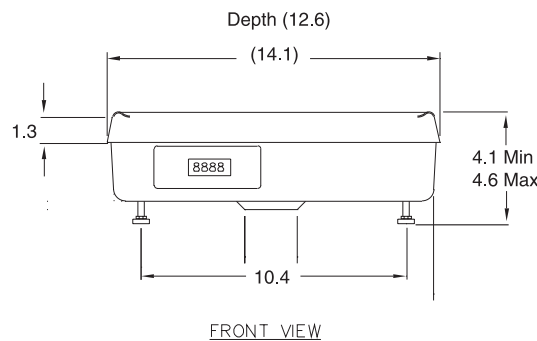

SPECIFICATIONS

- ◆ **Capacity/Resolution**

Pounds	Kilograms
15 x 0.005	7 x 0.002
30 x 0.01	15 x 0.005
60 x 0.02	30 x 0.01
- ◆ **Dimensions**

Weigh Platter:
12" x 14" (305 mm x 356 mm)
Adjustable Height:
4.1" – 4.6" (104 mm – 117 mm)
- ◆ **Power**

120 VAC (+10% -15%)/ 60 Hz (±3 Hz)
Standard 3 wire with ground
Output: 15 VDC @ 0.3 Amps minimum
- ◆ **Operating Environment**

41°F to 104°F (5°C to 40°C)
(Class III device)
10% to 90% RH (non-condensing)
- ◆ **Agency Approvals**

Legal for Trade, NTEP Class III,
USA COC #95-070A5
Canada: MOI approval #AM-5076 Rev. 2
Power Supply: UL Listed, CSA, CE Certified



© Avery Weigh-Tronix 2003. All rights reserved. This publication is issued to provide outline information only which, unless agreed by Avery Weigh-Tronix in writing, may not be regarded as a representation relating to the products or services concerned. Avery Weigh-Tronix reserves the right to alter without notice the specification, design, price or conditions of supply of any product or service.



As we continually strive to improve our products, specifications are necessarily subject to change without notice. Product complies with F.C.C..

Avery Berkel North America
3133 N 150 E
LaPorte, IN 46350

PH Toll-Free: 800-237-1886

PH: 219-325-9587

FAX Toll-Free: 800-237-2063

FAX: 219-325-9594

E-mail: sales@AveryBerkelUSA.com
Internet: <http://www.AveryBerkelUSA.com>

Avery Weigh-Tronix